



TECHNICAL SHEET 2020

SUPPLIER

YUNJI LIGHTING

SUPPLIER REFERENCE

SR-T6151/1 & SR-T6152/1

COREP REFERENCE

91901

DESCRIPTION

E27 CERAMIC LAMP, CHROME NECK,
SHADE Ø20H17, BASE Ø13.5

MASTER BY 6 PCS => 71x25x52 CM



TECHNICAL SHEET 2020

Item : SR-T6151/1 / 655409	
Base color	WHITE
Base finition	MATT
Shade	NATURAL RAPHIA
Lampholder color	WHITE
Wire color	WHITE
Protection	WRAPPING



HANGTAG CARTON LABEL ON PRODUCT

FRONT SIDE

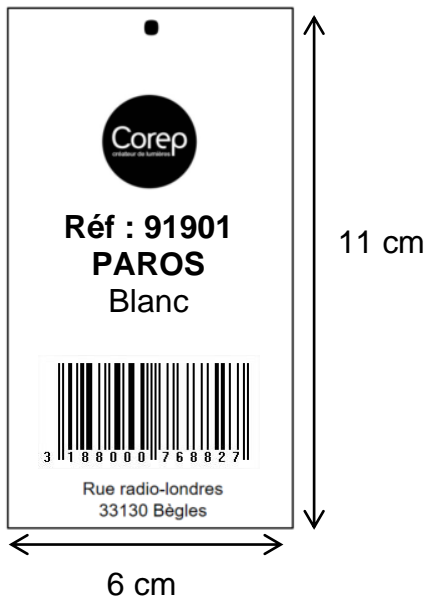

SHIPPING MARKS :

COREP ORDER XXXXX

TABLE LAMP REF 91901

QTY : 6 PCS

COLOR : WHITE

G.W :

N.W :

C/n°:

Label on MASTERPACK

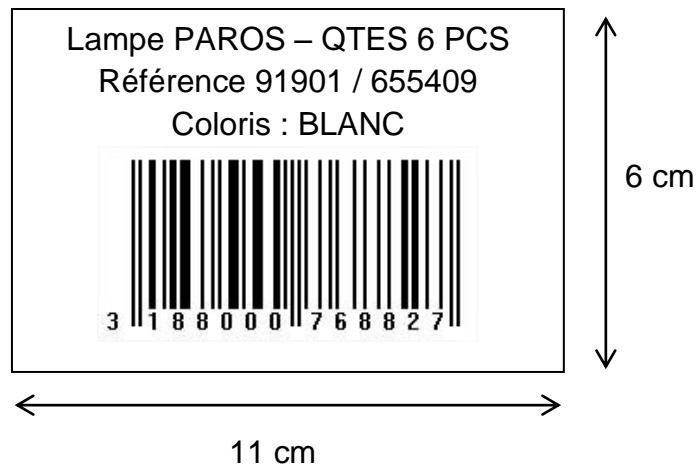

Fabrique Industrielle d'abat-jour – Lampes – Suspensions

Rue Radio-Londres CS 50001 – 33323 Bègles cedex France – Tél +33 556 491 366 - Fax + 33 556 497 838



TECHNICAL SHEET 2020

COLOR BOX

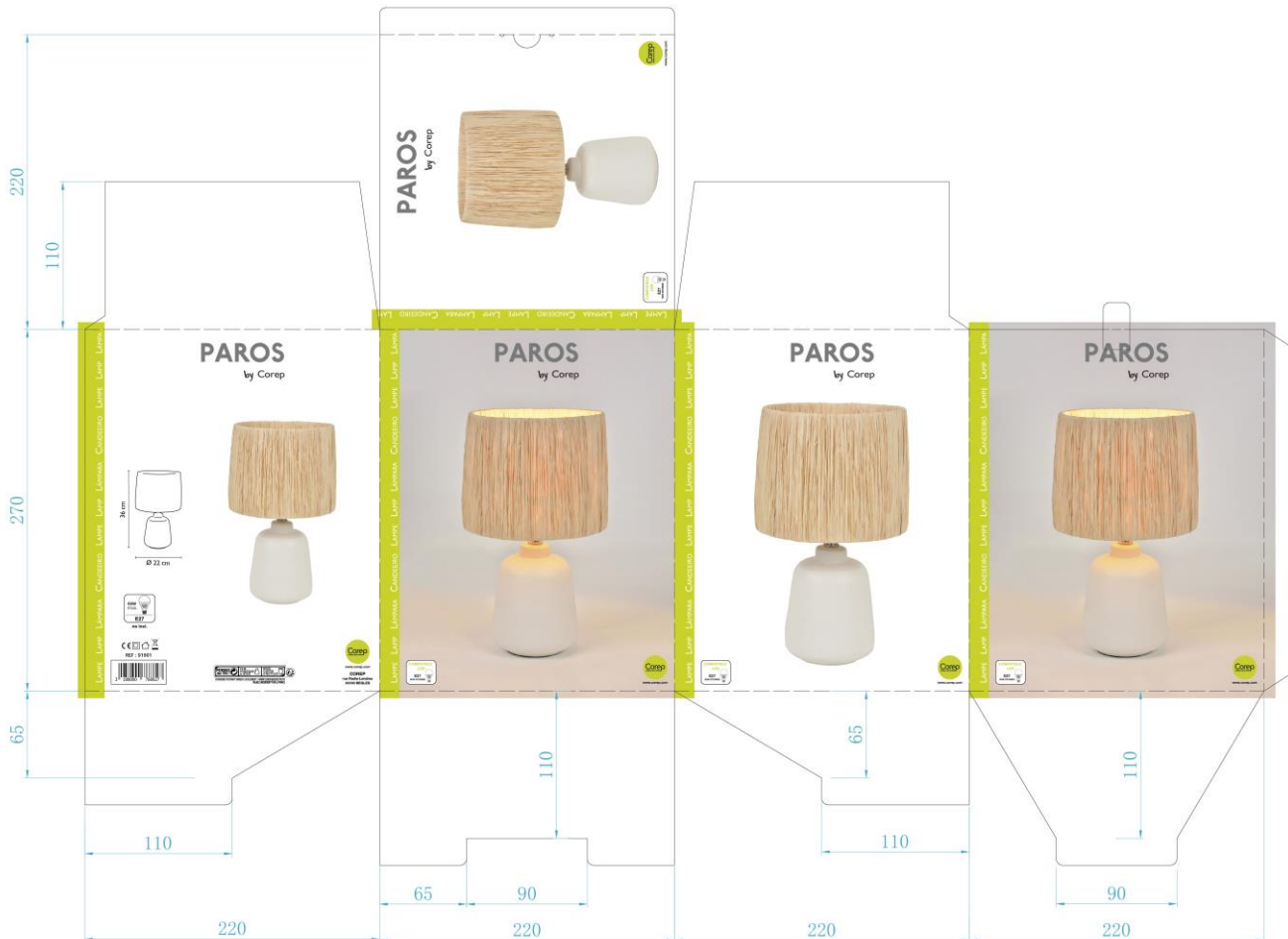

SR-T6152/1 彩盒



TECHNICAL SHEET 2020

Item : SR-T6152/1 / 655410	
Base color	TERRACOTTA 180C
Base finition	MATT
Shade	NATURAL PYLA
Lampholder color	WHITE
Wire color	WHITE
Protection	WRAPPING



HANGTAG CARTON LABEL ON PRODUCT

FRONT SIDE



SHIPPING MARKS :

COREP ORDER XXXXX

TABLE LAMP REF 91901

QTY : 6 PCS

COLOR : TERRACOTTA 180C

G.W :

N.W :

C/n°:

Label on MASTERPACK

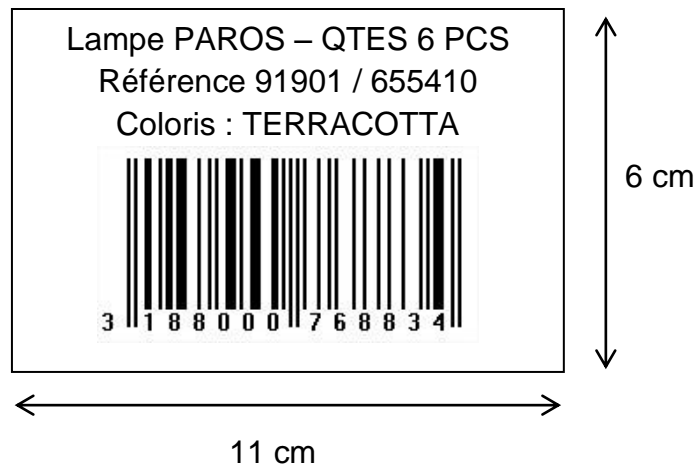



TECHNICAL SHEET 2020

COLOR BOX

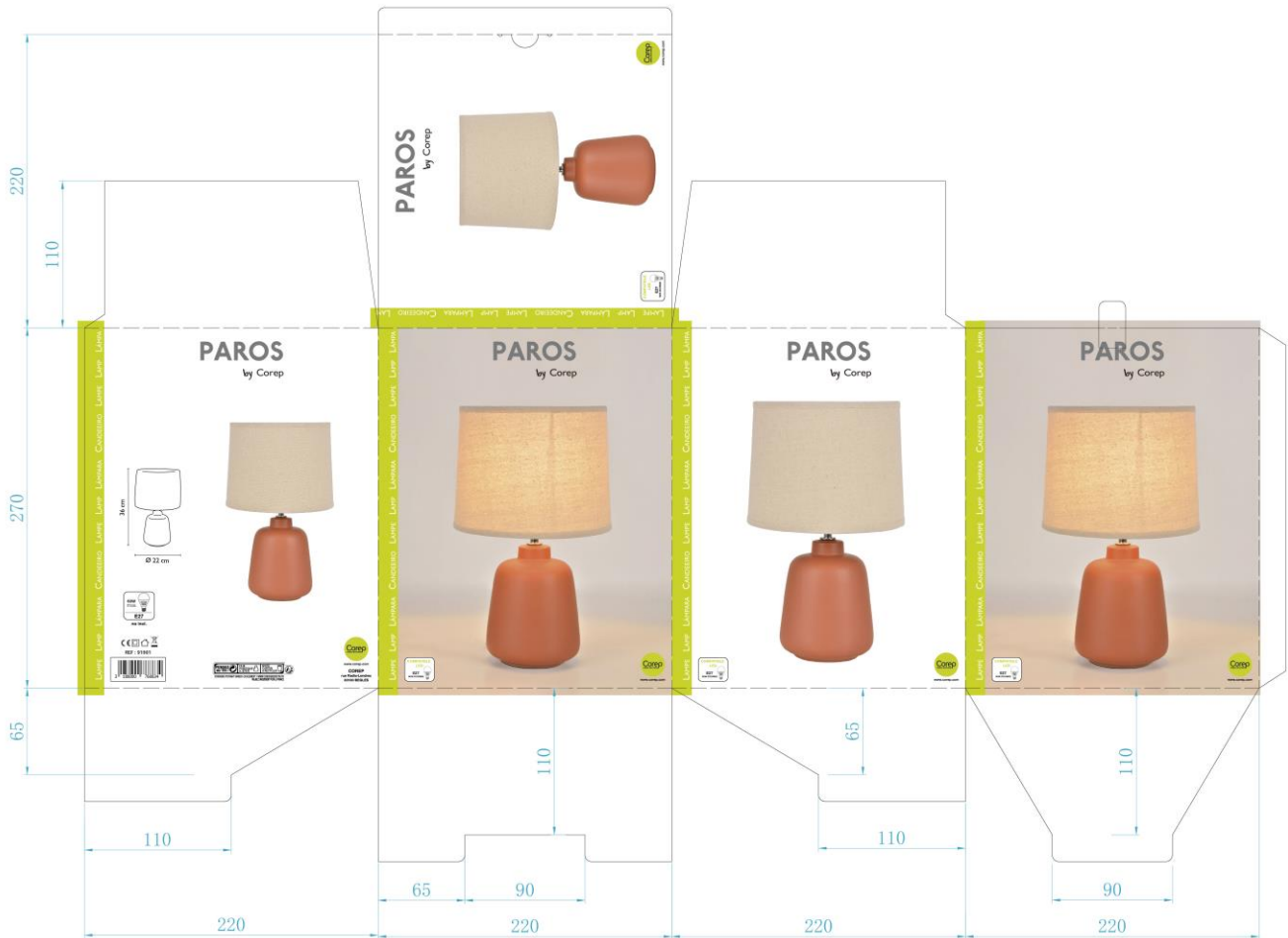

SR-T6152/1 彩盒



TECHNICAL SHEET 2020

DIMENSIONS REQUIREMENTS FOR HANGTAG CARTON LABEL ON PRODUCT

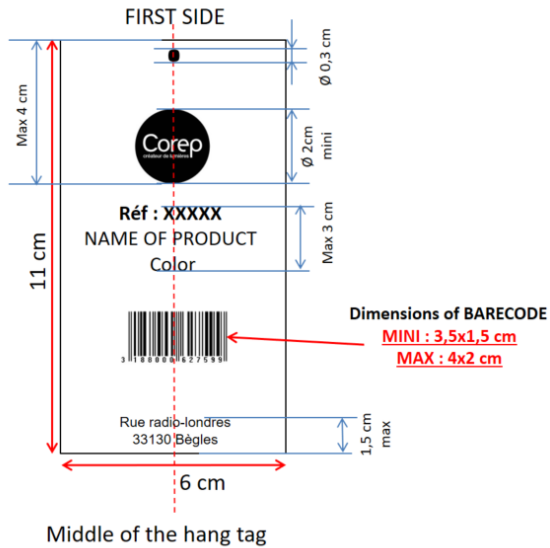

LABELS POSITION ON TABLE LAMPS

- Hangtag carton label around socket

>1 TAG
(DUPLEX
PRINTING)

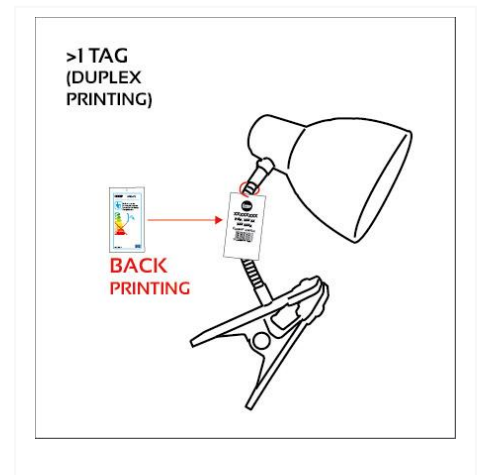
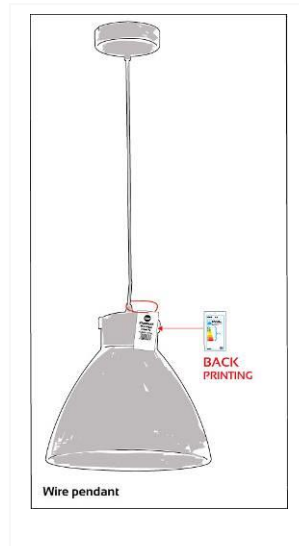
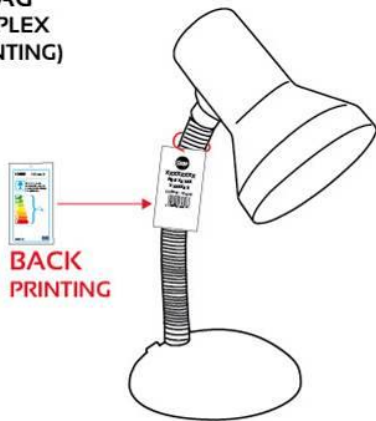

TECHNICAL SHEET 2020

CHECK POINT "PO NUMBER" labels

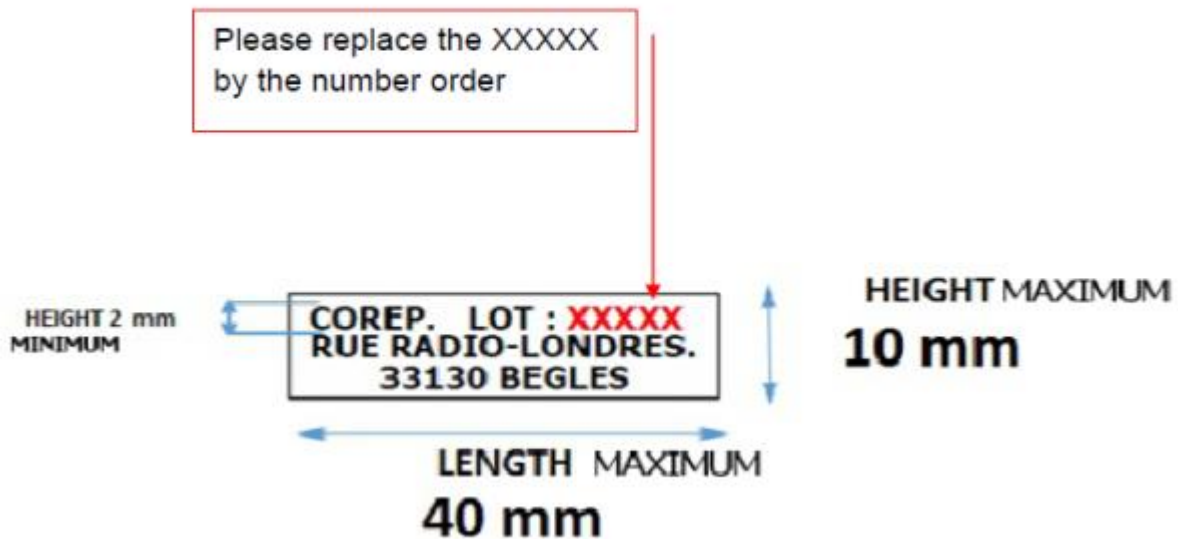

This label must be stuck as below indicated

Behind the switch

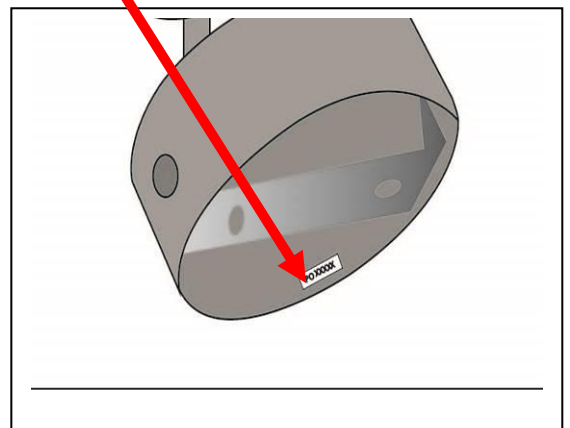

**Particularity for lamp/floor lamp/ desk lamp without switch cable (ex : rocket switch)
this label must be stuck under the base**



TECHNICAL SHEET 2020

LEGAL TEXT REQUIREMENTS ON ALL PLASTIC BAGS PROTECTION

TEXT for PELD material on the plastic bag

Please respect this dimensions and print the text in black color.
The square around the text is part of the impression.

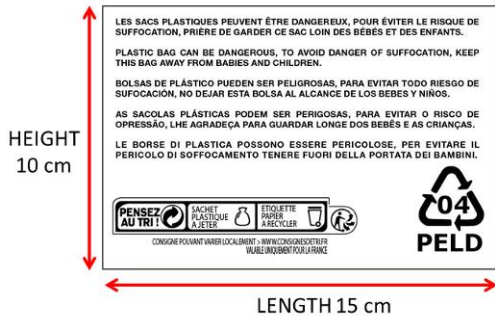

TEXT for PP material on the plastic bag

Please respect this dimensions and print the text in black color.
The square around the text is part of the impression.



OR

All plastic bags must have at least one hole to let enter the air in case of accident.

CHECK POINT INNER AND MASTERPACK

All packaging export inner + master must be in double groove (except for individual color box product)

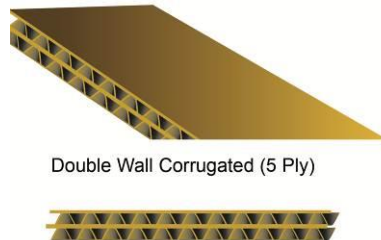

LOGOS to add all faces of the masterpack

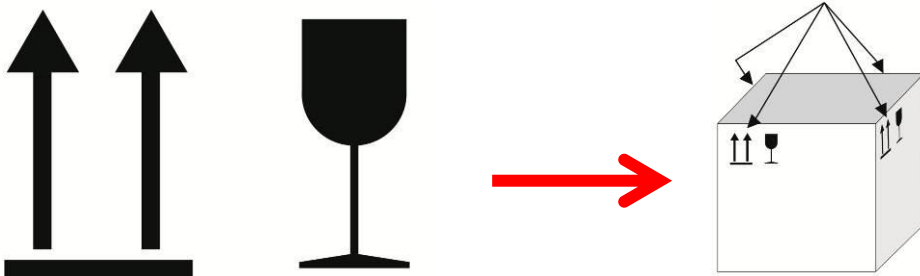



TECHNICAL SHEET 2020

Check the labels and logos placement on the individual and inner box

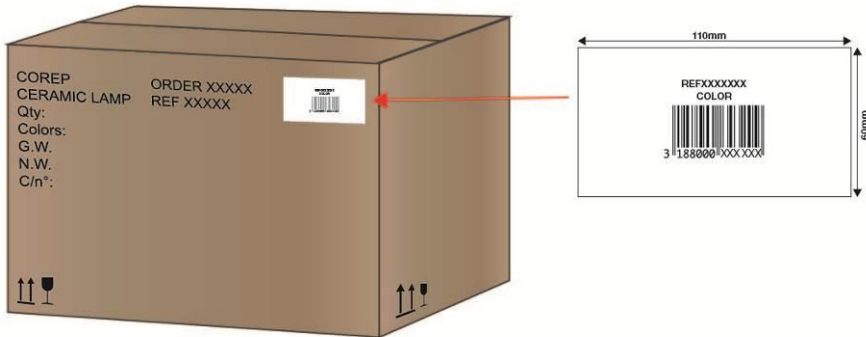

Any master pack must not be deformed

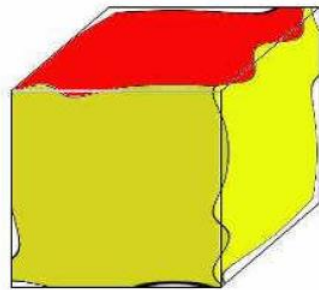



TECHNICAL SHEET 2020 QUALITY PART

PRODUCT DESCRIPTION:

SERIE: PC2E27

BULB TYPE: E27

POWER: 60W MAX

BULB INCLUDED: NO

WEIGHT: 0.940Kg **BE CAREFUL THE WEIGHT MUST NOT EXCEED 1Kg**

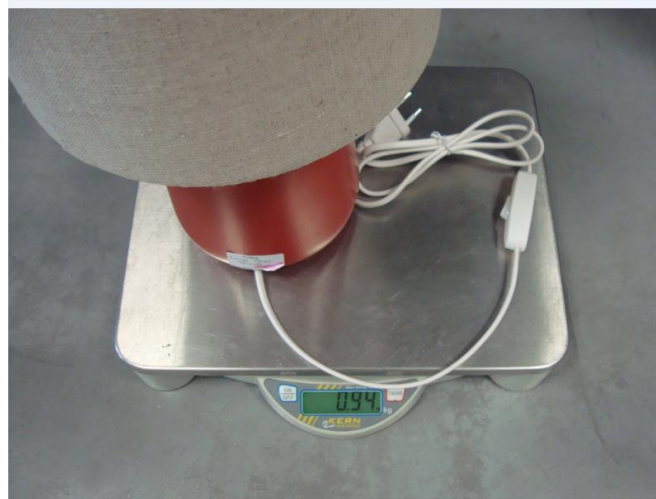

170mm





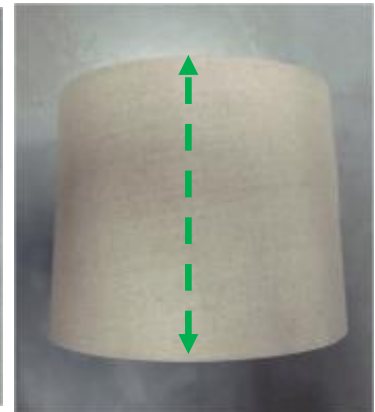
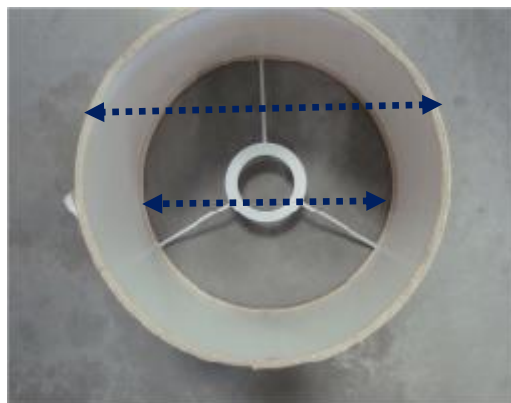

Ø210mm

Ø190mm



TECHNICAL SHEET 2020

➤ CHECK POINT COMPONENTS

CABLE : YONG RUI 2X0.50 mm² HO3VVH2-F	SWITCH: 8S 304
	
LAMPHOLDER : JIAZHAN E27 S 1 T 210°	PLUG: YONG RUI YR -101
	
GROMMET IN METAL TUBE	HOLE PROTECTED BY GROMMET, must be well fixed
	
FELT	
	

TECHNICAL SHEET 2020

➤ CHECK POINT INTERNAL ELECTRIC ASSEMBLY

INTERNAL CHECK WITH CORD GRIP.



CORD GRIP POSITION

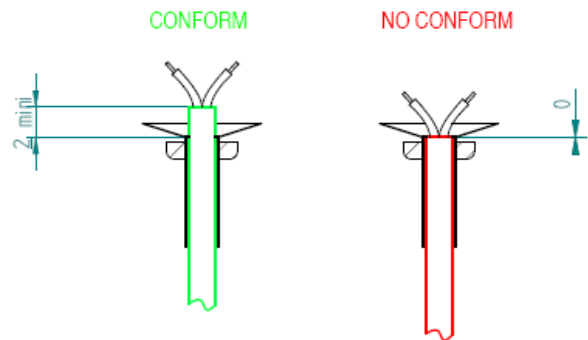



TECHNICAL SHEET 2020

➤ CHECK POINT STABILITY TEST



Conform to 6°



VERTICALITY TEST

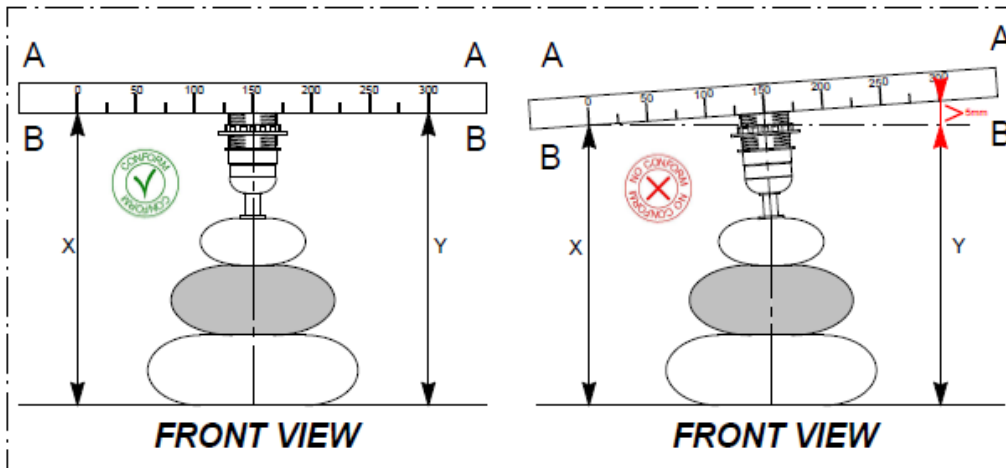
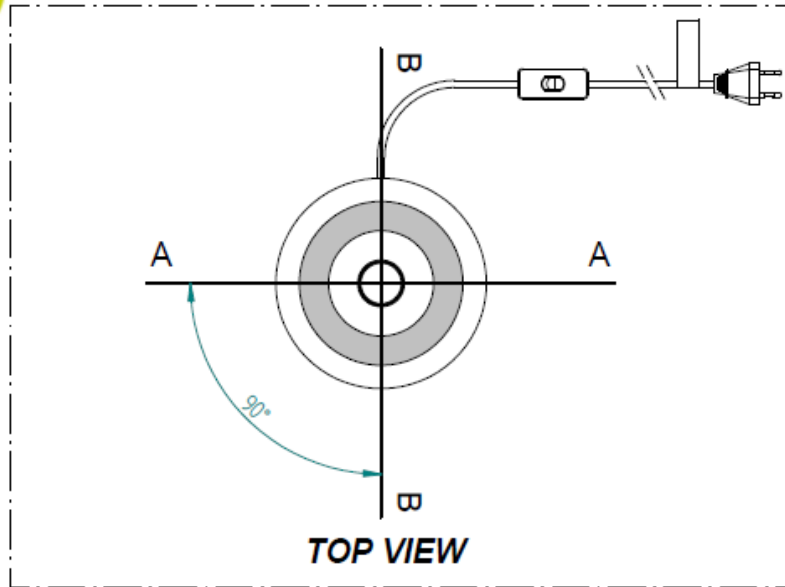

IF THE DIFFERENCE BETWEEN X & Y \leq 5mm



IF THE DIFFERENCE BETWEEN X & Y $>$ 5mm



TECHNICAL SHEET 2020

➤ CHECK POINT PULL TEST



HOW TO MAKE A PULL TEST

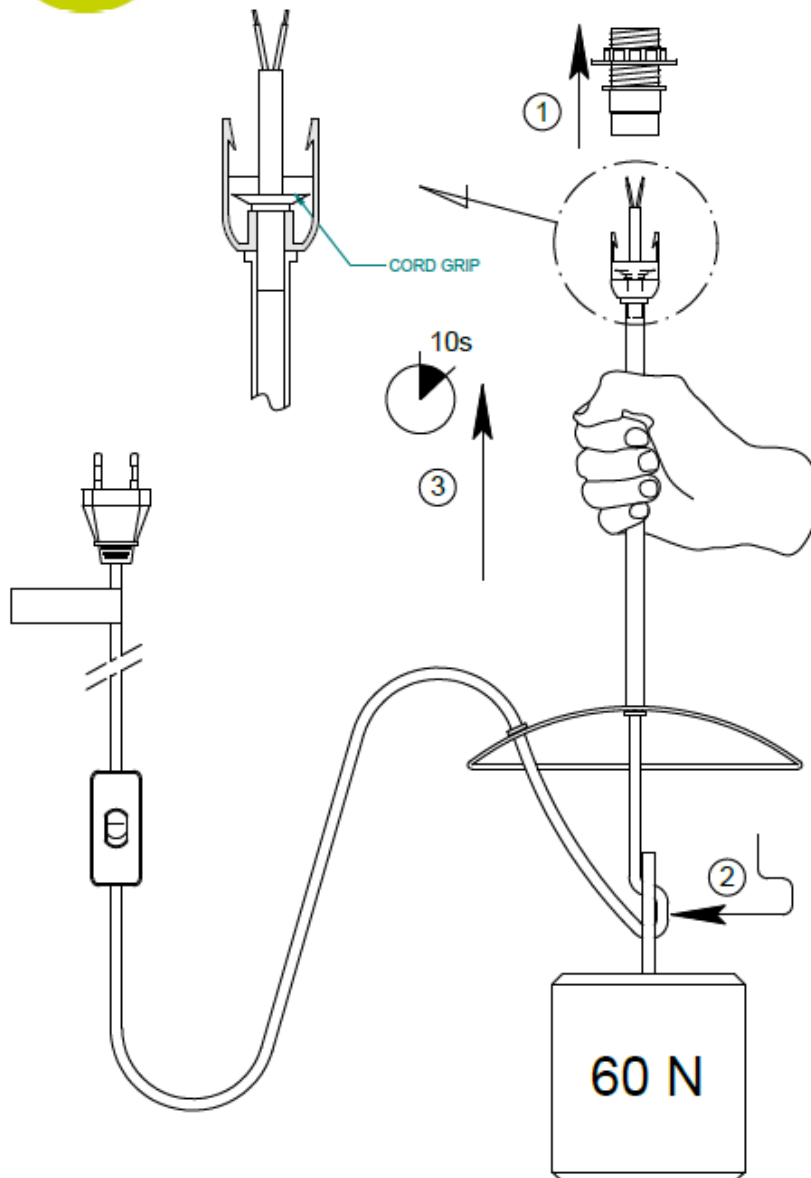

RESULT: **CONFORM** if the cordset haven't moved
FAIL if the cordset have moved



HOW TO MAKE A TORQUE TEST

weight position for E14

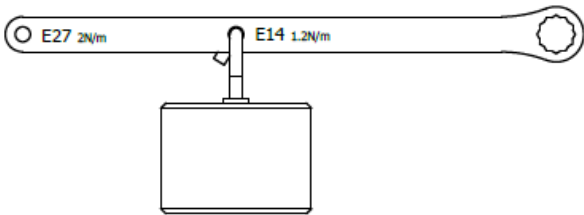

weight position for E27

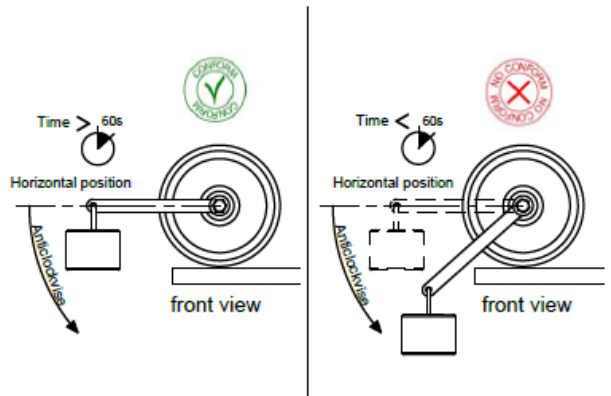
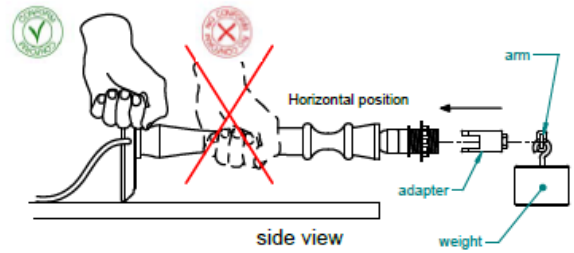
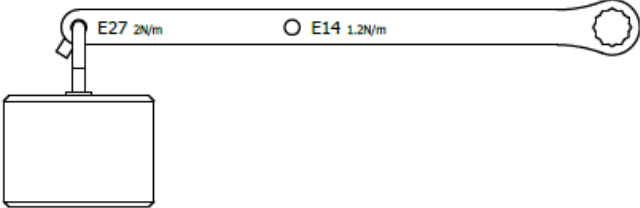

lampholder E14 ----> 1.2 N/m
lampholder E27 ----> 2 N/m





TECHNICAL SHEET 2020

➤ CHECK POINT LABELLING

WARNING

The durability of the marking is checked by trying to remove it by rubbing lightly for 15 s with a piece of cloth soaked with water and, after drying, for a further 15 s with a piece of cloth soaked with petroleum spirit.

The height of graphical symbols shall not be less than **5.5 mm** except that the symbols for class II and class III luminaires may be reduced to a minimum of 3 mm where the space available for marking is restricted. The height of letters and numerals either shown separately or with or as part of symbols shall not be less than **2.5 mm**.

CE LABEL:

THIS LABEL MUST BE GLUED AROUND THE LAMP HOLDER, STRAIGHT

POSITION ON THE PRODUCT

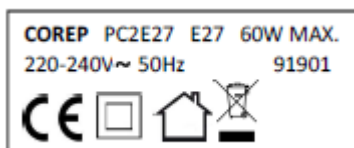



TECHNICAL SHEET 2020



rue Radio-Londres
33130 BEGLES
www.corep.com



Pour utilisation à l'intérieur uniquement

For indoor use only

Sólo para uso en interiores

Nur für den Innengebrauch

Solo per uso interno

Apenas para uso interno

Μόνο για εσωτερική χρήση

Alleen voor Gebruik binnenshuis

MPC/0720-A4A5

(FR) SI LE CÂBLE EXTÉRIEUR SOUPLE OU LE CORDON DE CE LUMINAIRE EST ENDOMMAGÉ, IL DOIT ÊTRE REMPLACÉ PAR LE FABRICANT, SON SERVICE DE MAINTENANCE OU TOUTE PERSONNE DE QUALIFICATION ÉQUIVALENTE, CECI AFIN D'ÉVITER TOUT RISQUE.

(EN) IF THE FLEXIBLE EXTERNAL CABLE OR THE CORD OF THIS LAMP IS DAMAGED, IT MUST BE REPLACED BY THE MANUFACTURER, ITS MAINTENANCE SERVICE OR ANY EQUIVALENT QUALIFICATION PERSON, THIS IN ORDER TO AVOID ALL RISK.

(ES) SI EL CABLE EXTERIOR FLEXIBLE O EL CABLE DE ESTE ACCESORIO ESTÁ DAÑADO, DEBE SER REEMPLAZADO POR EL FABRICANTE, SU SERVICIO DE MANTENIMIENTO O CUALQUIERA PERSONA DE CALIFICACIÓN EQUIVALENTE, ESTO PARA EVITAR TODO RIESGO

(IT) SE IL CAVO ESTERNO FLESSIBILE O IL CAVO DI QUESTA STRUTTURA È DANNEGGIATO, DEVE ESSERE SOSTITUITO DAL FABBRICANTE, DAL SUO SERVIZIO DI MANUTENZIONE O DA QUALUNQUE EQUIVALENTE PERSONALE DI QUALIFICAZIONE, QUESTO PER EVITARE TUTTI I RISCHI

(D) WENN DAS FLEXIBLE AUSSENKABEL ODER DAS KABEL DIESER BEFESTIGUNG BESCHÄDIGT IST, ES MUSS VOM HERSTELLER, SEINEM WARTUNGSDIENST ODER JEDLICHEM ERSETZT WERDEN ÄQUIVALENTE QUALIFIKATIONSPERSON, UM ALLE RISIKEN ZU VERMEIDEN

(P) SE O CABO EXTERIOR FLEXÍVEL OU O CABO DESTA FIXA ESTIVER DANIFICADO, DEVE SER SUBSTITUÍDO PELO FABRICANTE, SEU SERVIÇO DE MANUTENÇÃO OU QUALQUER PESSOA DE QUALIFICAÇÃO EQUIVALENTE, PARA EVITAR TODOS OS RISCOS

(NL) ALS DE FLEXIBELE BUITENKABEL OF HET KABEL VAN DIT ARMATUUR BESCHADIGD IS, DEZE MOET WORDEN VERVANGEN DOOR DE FABRIKANT, HAAR ONDERHOUDSDIENST OF ENIGE GELIJKWAARDIGE KWALIFICATIEPERSOON, DIT OM ALLE RISICO'S TE VOORKOMEN

(GC) ΕΑΝ ΕΙΝΑΙ ΕΥΕΛΙΚΟ ΕΞΩΤΕΡΙΚΟ ΚΑΛΩΔΙΟ Ή ΚΑΛΩΔΙΟ ΑΥΤΟΥ ΤΟΥ ΣΧΕΔΙΟΥ ΕΙΝΑΙ ΖΗΜΙΑ, ΠΡΕΠΕΙ να αντικατασταθεί από τον ΚΑΤΑΣΚΕΥΑΣΤΗ, ΤΗΝ ΥΠΗΡΕΣΙΑ ΣΥΝΤΗΡΗΣΗΣ ΤΗΣ Ή ΟΠΟΙΑΔΗΠΟΤΕ ΙΣΟΔΥΝΑΤΙΚΟ ΠΡΟΣΩΠΙΚΟ ΠΡΟΣΩΠΙΚΟ, ΑΥΤΟ ΤΟ ΠΑΡΑΓΙΤΕΛΙΑ ΓΙΑ ΝΑ ΑΠΟΦΥΓΕΤΕ ΟΛΟ ΤΟΝ ΚΙΝΔΥΝΟ

RECYCLAGE
Produit soumis à la directive européenne 2012/19/UE : les produits électriques, électroniques, batteries et accumulateurs doivent faire l'objet d'un tri sélectif. Veuillez à déposer votre produit hors d'usage dans une poubelle appropriée, ou le restituer dans un point de collecte. Les collectivités ou les revendeurs vous communiqueront toutes les informations concernant l'élimination de votre ancien produit. Ne pas mettre au rebut avec vos déchets ménagers permet de protéger l'environnement et la santé

RECYCLING
Product subject to European Directive 2012/19 / EU: electrical, electronic products, batteries and accumulators must be subject to selective sorting. Be sure to put your product out of use in an appropriate bin, or return it to a collection point. Local authorities or resellers will provide you with all the information regarding the disposal of your old product. Not disposing of it with your household waste can protect the environment and human health

RECICLAJE
Producto sujeto a la Directiva Europea 2012/19 / UE: los productos eléctricos, electrónicos, baterías y acumuladores deben estar sujetos a clasificación selectiva. Asegúrese de dejar su producto fuera de uso en un contenedor apropiado o devolverlo a un punto de recolección. Las autoridades locales o los revendedores le proporcionarán toda la información sobre la eliminación de su producto anterior. No desechar con la basura doméstica puede proteger el medio ambiente y la salud

RECYCLING
Produkt, das der europäischen Richtlinie 2012/19 / EU unterliegt: Elektrische, elektronische Produkte, Batterien und Akkumulatoren müssen selektiv sortiert werden. Stellen Sie sicher, dass Ihr Produkt nicht in einem geeigneten Behälter verwendet wird, oder bringen Sie es zu einer Sammelstelle zurück. Die örtlichen Behörden oder Wiederverkäufer stellen Ihnen alle Informationen zur Entsorgung Ihres alten Produkts zur Verfügung. Nicht mit dem Hausmüll entsorgen, da dies die Umwelt und die Gesundheit schützen kann

RACCOLTA DIFFERENZIATA
Prodotto soggetto alla Direttiva Europea 2012/19 / UE: prodotti elettrici, elettronici, batterie e accumulatori devono essere soggetti a selezione selettiva. Assicurati di mettere il prodotto fuori uso in un cestino appropriato o di restituirlo a un punto di raccolta. Le autorità o i rivenditori locali ti forniranno tutte le informazioni relative allo smaltimento del tuo vecchio prodotto. Non smaltire insieme ai rifiuti domestici può proteggere l'ambiente e la salute

RECLANDO
Produto sujeito à Diretiva Europeia 2012/19 / UE: produtos elétricos, eletrônicos, baterias e acumuladores devem estar sujeitos a triagem seletiva. Certifique-se de colocar o produto fora de uso em uma lixeira apropriada ou devolvê-lo a um ponto de coleta. As autoridades ou revendedores locais fornecerão todas as informações sobre o descarte do seu produto antigo. Não elimine com o lixo doméstico, pode proteger o meio ambiente e a saúde

ΑΝΑΚΥΚΛΩΣΗ
Προϊόν που υπακούει στην Ευρωπαϊκή Οδηγία 2012/19 / ΕΕ: τα ηλεκτρικά, ηλεκτρονικά προϊόντα, οι μπαταρίες και οι συσσωρευτές πρέπει να υποκείνται σε επιλεκτική ταξινόμηση. Φροντίστε να θέσετε το προϊόν σας εκτός χρήσης σε κατάλληλο κάδο ή να το επιστρέψετε σε σημείο συλλογής. Οι τοπικές αρχές ή οι μεταπωλητές θα σας παρέχουν όλες τις πληροφορίες σχετικά με τη διάθεση του παλιού σας προϊόντος. Μην απορρίπτετε με τα οικιακά σας απορρίμματα μπορεί να προστατίσει το περιβάλλον και την υγεία

RECYCLING
Product onderworpen aan de Europese richtlijn 2012/19 / EU: elektrische, elektronische producten, batterijen en accu's moeten selectief worden gesorteerd. Zorg ervoor dat u uw product niet gebruikt in een geschikte bak of breng het terug naar een inzameelpunt. Lokale autoriteiten of wiederverkopers zullen u alle informatie geven over de verwijdering van uw oude product. Gooi het niet weg met uw huishoudelijk afval dat het milieu en de gezondheid kan beschermen



Fabrique Industrielle d'abat-jour – Lampes – Suspensions

Rue Radio-Londres CS 50001 – 33323 Bègles cedex France – Tél +33 556 491 366 - Fax + 33 556 497 838



TECHNICAL SHEET 2020

➤ CHECK POINT PRODUCTS PARTICULARITIES

THE PRODUCT MUST BE STRAIGHT WITHOUT ANY
SCRATCHES, MISSING CERAMIC PARTS, CERAMIC SHARPS,
GLUE MARKS ON THE BASE AND CABLE

**THE TORQUE TEST AND THE VERTICALITY TEST MUST BE 100%
CONFORM.**

THE BUSHING IN THE CERAMIC BASE MUSTN'T MOVE.